

# HYDRAULICS SLEWING

## RALLA IDRAULICA

- > La ralla idraulica può essere montata mediante l'attacco all'escavatore
- > La rotazione idraulica permette all'attrezzatura di ruotare su se stessa di 320° in rotazione parziale

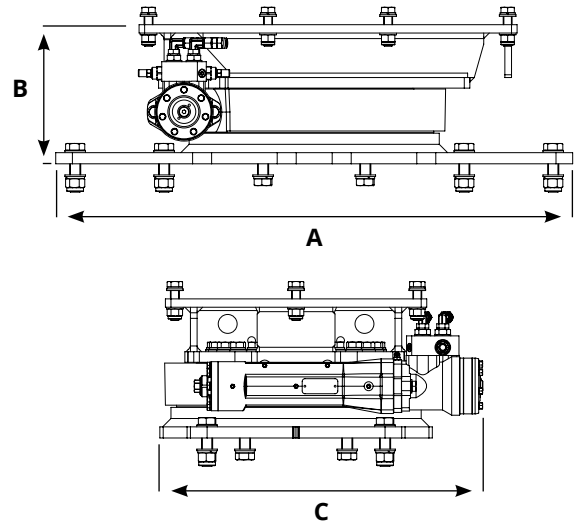
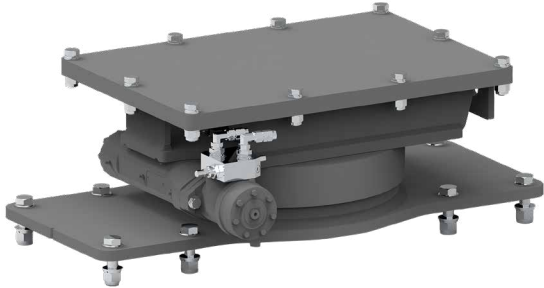

Model	A mm	B mm	C mm	Max Rotation	Kg.	Model. PLURY
HYDRAULICS SLEWING 7/15 ton	650	245	526	320°	170	W1 65.0   W1 95.0   W2 60.0   W2 80.0
HYDRAULICS SLEWING 12/20 ton	720	245	526	320°	175	W2 100.0   W2 120.0
HYDRAULICS SLEWING 18/40 ton	930	250	581	320°	260	W2 150.0   W2 180.0

