

KIT DRAINAGE PLURY
Max. Gegendruck
15 BAR

PLURY	W1 9.0 TONS 1.0 - 2.0	W1 15.0 TONS 1.5 - 4.0	W1 15.0 TONS 1.5 - 4.0	W1 15.0 TONS 1.5 - 4.0	W1 27.0 TONS 4.0 - 6.5	W1 27.0 TONS 4.0 - 6.5	W1 27.0 TONS 4.0 - 6.5
A (mm)	480	525	525	525	680	680	680
B (mm)	366	430	430	430	540	540	540
C (mm)	210	210	210	210	272	272	272
D (mm)	290	290	290	290	395	395	395
Gewicht (Kg)	72	105	105	105	187	187	187
Motor (CC)	11	11	14	17	21	27	32
Öldurchsatz (L/Min)	23	23	31	37	45	57	69
Druck (BAR)	200/220	200/220	200/220	200/220	200/220	200/220	200/220
U/min (RPM)	2.130	2.130	2.153	2.173	2.133	2.111	2.143
Zentrifugalkraft (Kn)	9	15	15	15	27	27	27
Hertz	35	36	36	36	36	36	36
Max. Gegendruck (BAR)	15	15	15	15	15	15	15

PLURY	W1 40.0 TONS 5.0 - 6.5	W1 40.0 TONS 5.0 - 6.5	W1 40.0 TONS 5.0 - 6.5	W1 65.0 TONS 7.0 - 15.0	W1 65.0 TONS 7.0 - 15.0	W1 65.0 TONS 7.0 - 15.0	W1 95.0 TONS 8.0 - 22.0	W1 95.0 TONS 8.0 - 22.0	W1 95.0 TONS 8.0 - 22.0
A (mm)	680	680	680	840	840	840	840	840	840
B (mm)	540	540	540	670	670	670	670	670	670
C (mm)	272	272	272	332	332	332	332	332	332
D (mm)	395	395	395	515	515	515	515	515	515
Gewicht (Kg)	190	190	190	330	330	330	340	340	340
Motor (CC)	21	27	32	32	43	47	32	43	51
Öldurchsatz (L/Min)	45	57	69	69	93	101	69	93	101
Druck (BAR)	200/220	200/220	200/220	200/220	200/220	200/220	200/220	200/220	200/220
U/min (RPM)	2.133	2.111	2.143	2.133	2.111	2.143	2.133	2.111	2.143
Zentrifugalkraft (Kn)	40	40	40	65	65	65	95	95	95
Hertz	36	36	36	36	36	36	36	36	36
Max. Gegendruck (BAR)	15	15	15	15	15	15	15	15	15

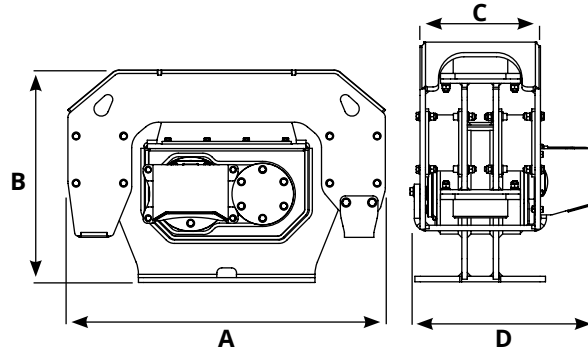



KIT DRAINAGE PLURY
Max. Gegendruck
15 BAR

PLURY	W2 60.0	W2 60.0	W2 60.0	W2 80.0	W2 80.0	W2 80.0	W2 100.0	W2 100.0	W2 100.0
	TONS 8.0 - 14.0	TONS 8.0 - 14.0	TONS 8.0 - 14.0	TONS 10.0 - 15.0	TONS 10.0 - 15.0	TONS 10.0 - 15.0	TONS 12.0 - 18.0	TONS 12.0 - 18.0	TONS 12.0 - 18.0
A (mm)	970	970	970	970	970	970	1030	1030	1030
B (mm)	650	650	650	650	650	650	735	735	735
C (mm)	330	330	330	330	330	330	395	395	395
D (mm)	490	490	490	490	490	490	560	560	560
Gewicht (Kg)	353	353	353	362	362	362	525	525	525
Motor (CC)	32	43	47	32	43	47	43	47	51
Öldurchsatz (L/Min)	69	93	101	69	93	101	93	100	110
Druck (BAR)	200/220	200/220	200/220	200/220	200/220	200/220	200/220	200/220	200/220
U/min (RPM)	2.133	2.148	2.143	2.133	2.148	2.143	2.143	2.149	2.157
Zentrifugalkraft (Kn)	60	60	60	80	80	80	100	100	100
Hertz	36	36	36	36	36	36	36	36	36
Max. Gegendruck (BAR)	15	15	15	15	15	15	15	15	15

PLURY	W2 120.0	W2 120.0	W2 120.0	W2 150.0	W2 180.0
	TONS 14.0 - 20.0	TONS 14.0 - 20.0	TONS 14.0 - 20.0	TONS 18.0 - 35.0	TONS 20.0 - 40.0
A (mm)	1030	1030	1030	1220	1220
B (mm)	735	735	735	920	920
C (mm)	395	395	395	440	440
D (mm)	560	560	560	710	710
Gewicht (Kg)	533	533	533	827	837
Motor (CC)	43	47	51	63	63
Öldurchsatz (L/Min)	93	100	110	135	135
Druck (BAR)	200/220	200/220	200/220	250/300	250/300
U/min (RPM)	2.143	2.149	2.157	2.143	2.143
Zentrifugalkraft (Kn)	120	120	120	150	180
Hertz	36	36	36	36	36
Max. Gegendruck (BAR)	15	15	15	15	15

GRAPPLE

HOLZGREIFER MIT PFAHLRAMME

- › Entwickelt für das Vibro-Eintreiben und Ziehen von Holz-, Beton- und Stahlpfosten
- › Geeignet für die Eindämmung von Erdbeben, Docks und Böschungen
- › Bau von Weinbergen, Obstplantagen und Zäunen
- › Eine grundlegende Kombination, die in der Gebietserhaltung und Landwirtschaft Verwendung findet

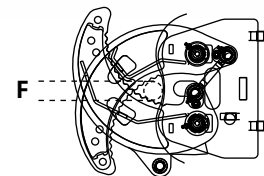
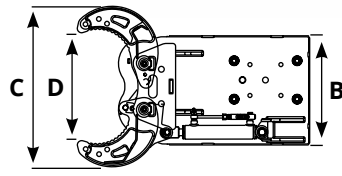
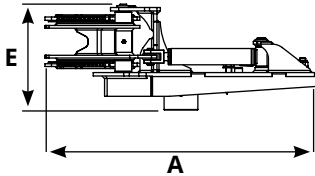
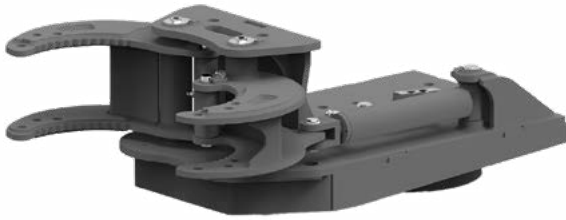

Model	A mm	B mm	C mm	D mm	E mm	F Ø mm	Kg.	Model. PLURY
GRAPPLE 1/4 ton	810	380	560	375	310	35	75	W1 9.0 W1 15.0
GRAPPLE 4/6.5 ton	1090	460	665	425	420	55	159	W1 27.0 W1 40.0
GRAPPLE 7/15 ton	1575	705	870	560	520	140	365	W1 65.0 W2 60.0 W2 80.0
GRAPPLE 8/20 ton	1590	705	870	570	520	140	375	W1 95.0 W2 100.0 W2 120.0
GRAPPLE 18/40 ton	1730	705	870	560	530	140	380	W2 150.0 W2 180.0

Öldurchsatz (L/Min) 10

Max. Gegendruck (BAR) 200



Grapple bietet die Möglichkeit, die maßgeschneiderte Glocke zu montieren, die je nach Bedarf in verschiedenen Durchmessern erhältlich ist. Die Glocke ist im Preis des Greifers enthalten.

Model	A mm	B mm	C mm	Kg	Model. PLURY
BELL 150 - 1/4 ton	150	200	125	15	W1 9.0 W1 15.0
BELL 200 - 1/4 ton	200	250	125	20	W1 9.0 W1 15.0
BELL 150 - 4/6.5 ton	150	200	105	11	W1 27.0 W1 40.0
BELL 200 - 4/6.5 ton	200	250	125	22	W1 27.0 W1 40.0
BELL 250 - 4/6.5 ton	250	300	145	28	W1 27.0 W1 40.0
BELL 150 - 7/40 ton	150	200	105	17	W1 65.0 W1 95.0 W2 60.0 W2 80.0 W2 100.0 W2 120.0 W2 150.0 W2 180.0
BELL 200 - 7/40 ton	200	250	105	20	W1 65.0 W1 95.0 W2 60.0 W2 80.0 W2 100.0 W2 120.0 W2 150.0 W2 180.0
BELL 250 - 7/40 ton	250	300	125	22	W1 65.0 W1 95.0 W2 60.0 W2 80.0 W2 100.0 W2 120.0 W2 150.0 W2 180.0
BELL 300 - 7/40 ton	300	350	180	43	W1 65.0 W1 95.0 W2 60.0 W2 80.0 W2 100.0 W2 120.0 W2 150.0 W2 180.0
BELL 350 - 7/40 ton	350	400	180	50	W1 65.0 W1 95.0 W2 60.0 W2 80.0 W2 100.0 W2 120.0 W2 150.0 W2 180.0

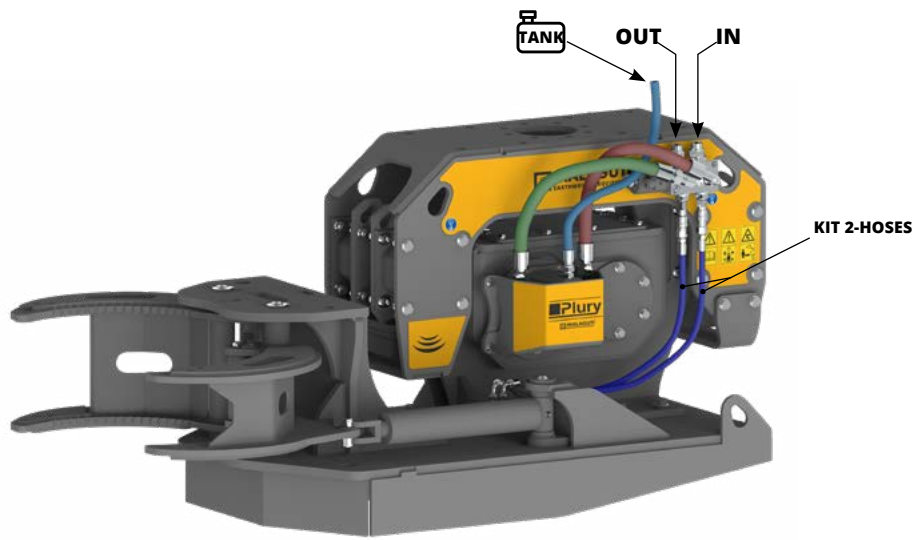

Model KIT	HYDRAULIC KITS	Model. PLURY	Motor (cc)	Cod.
KIT A - PLURY	VENTIL-KIT 2 SCHLÄUCHE 12 VOLT	W1 9.0 W1 15.0	11	HII0201013
KIT B - PLURY	VENTIL-KIT 2 SCHLÄUCHE 12 VOLT	W1 27.0 W1 40.0	21 27 32	HII0201006
KIT C - PLURY	VENTIL-KIT 2 SCHLÄUCHE 24 VOLT	W1 27.0 W1 40.0	21 27 32	HII0201035
KIT D - PLURY	VENTIL-KIT 2 SCHLÄUCHE 12 VOLT	W1 65.0 W1 95.0 W2 60.0 W2 80.0 W2 100.0 W2 120.0	32 43 47 51	HII0201010
KIT E - PLURY	VENTIL-KIT 2 SCHLÄUCHE 24 VOLT	W1 65.0 W1 95.0 W2 60.0 W2 80.0 W2 100.0 W2 120.0	32 43 47 51	HII0201037
KIT F - PLURY	VENTIL-KIT 2 SCHLÄUCHE 12 VOLT	W2 150.0 W2 180.0	63	HII0201012
KIT G - PLURY	VENTIL-KIT 2 SCHLÄUCHE 24 VOLT	W2 150.0 W2 180.0	63	HII0201038



Model	Model. PLURY	Cod.
A - 2 SCHLÄUCHE GRAPPLE	W1 9.0 W1 15.0	HII0201020
B - 2 SCHLÄUCHE GRAPPLE	W1 27.0 W1 40.0	HII0201022
C - 2 SCHLÄUCHE GRAPPLE	W1 65.0 W1 95.0 W2 60.0 W2 80.0	HII0201024
D - 2 SCHLÄUCHE GRAPPLE	W2 100.0 W2 120.0	HII0201026
C - 2 SCHLÄUCHE GRAPPLE	W2 150.0 W2 180.0	HII0201028



Model	Cod.
ELEKTRO-KIT	C030201020

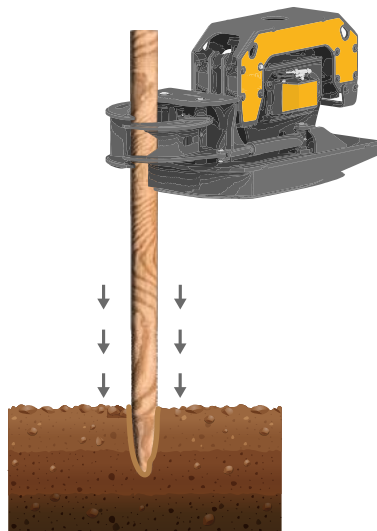

OPTIONAL GRAPPLE KIT

OPTIONAL BETON-STAHL

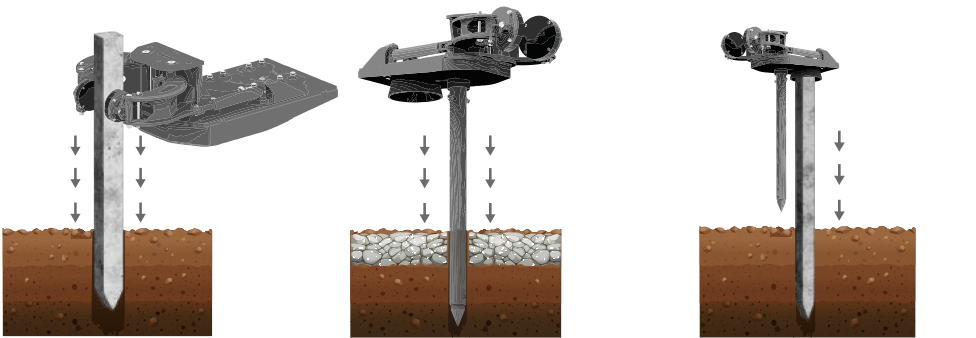
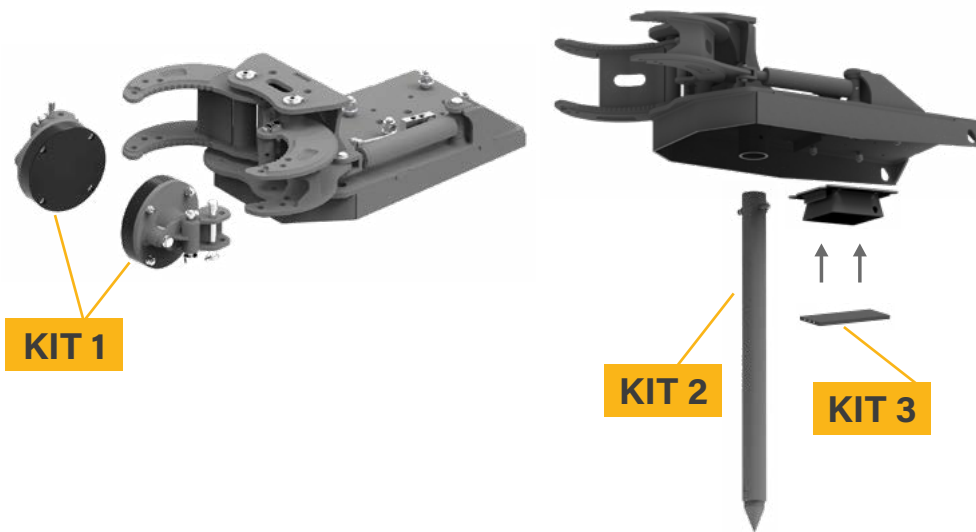

KIT 1

- › Zangenzubehör zum Vibro-Eintreiben und Ziehen von Beton- und Stahl Pfählen an alle Greifzange für Holz Tonnagen montierbar

KIT 2

- › Vorbohrspitze geeignet zum Vorbohren auf hartem Untergrund
- › Geeignet zum Vibro-Eintreiben von Beton Pfählen

KIT 3

- › Zubehör aus stoßdämpfendem Gummi, geeignet zum Vibro-Eintreiben von Beton Pfählen, um Beschädigungen der Pfahl selbst zu vermeiden

OPTIONALES ZAHNSCHAUFEL

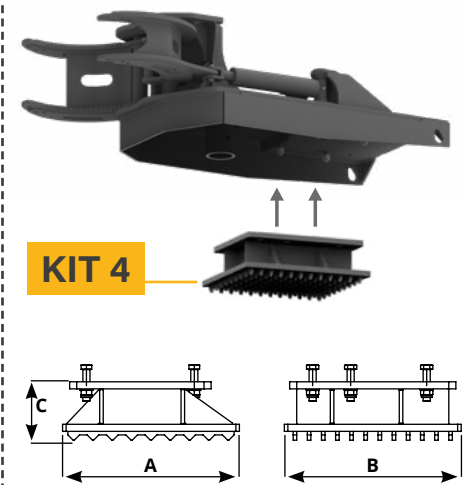

KIT 4

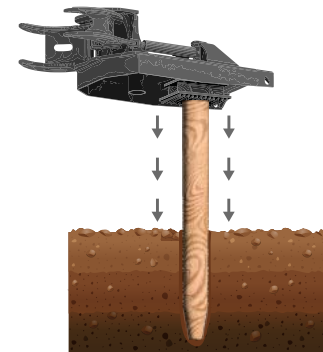

KIT 4

- › Zahnschaufel, die anstelle der Glocke für die Vibrationseinbringung von Holzpfählen unterschiedlicher Durchmesser montiert wird

Model	A mm	B mm	C mm	Kg.	Model. GRAPPLE
KIT 1 - 1/4 ton	/	/	/	16	GRAPPLE 1/4 ton
KIT 2 - 1/6.5 ton	/	/	/	22	
KIT 3 for Bell	Je nach Art der Bell				
KIT 4 - 1/4 ton	335	270	120	23	

Model	A mm	B mm	C mm	Kg.	Model. GRAPPLE
KIT 1 - 4/6.5 ton	/	/	/	20	GRAPPLE 4/6.5 ton
KIT 2 - 1/6.5 ton	/	/	/	22	
KIT 3 for Bell	Je nach Art der Bell				
KIT 4 - 4/6.5 ton	350	400	130	44	

Model	A mm	B mm	C mm	Kg.	Model. GRAPPLE
KIT 1 - 7/40 ton	/	/	/	24	GRAPPLE 7/15 ton
KIT 2 - 7/20 ton	/	/	/	27	
KIT 3 for Bell	Je nach Art der Bell				GRAPPLE 8/20 ton
KIT 4 - 7/20 ton	500	500	165	90	

Model	A mm	B mm	C mm	Kg.	Model. GRAPPLE
KIT 1 - 7/40 ton	/	/	/	24	GRAPPLE 18/40 ton
KIT 2 - 18/40 ton	/	/	/	43	
KIT 3 for Bell	Je nach Art der Bell				
KIT 4 - 18/40 ton	540	500	175	100	