

DRAINAGE KIT PLURY
back pressure
MAX 15 BAR

PLURY	W1 9.0 TONS 1.0 - 2.0	W1 15.0 TONS 1.5 - 4.0	W1 15.0 TONS 1.5 - 4.0	W1 15.0 TONS 1.5 - 4.0	W1 27.0 TONS 4.0 - 6.5	W1 27.0 TONS 4.0 - 6.5	W1 27.0 TONS 4.0 - 6.5
A (mm)	480	525	525	525	680	680	680
B (mm)	366	430	430	430	540	540	540
C (mm)	210	210	210	210	272	272	272
D (mm)	290	290	290	290	395	395	395
Weight (Kg)	72	105	105	105	187	187	187
Engine (CC)	11	11	14	17	21	27	32
Hydraulic Fluid Flow Rate (L/Min)	23	23	31	37	45	57	69
Pressure (BAR)	200/220	200/220	200/220	200/220	200/220	200/220	200/220
Rev/min (RPM)	2.130	2.130	2.153	2.173	2.133	2.111	2.143
Centrifugal force (Kn)	9	15	15	15	27	27	27
Hertz	35	36	36	36	36	36	36
Back press. Max. (BAR)	15	15	15	15	15	15	15

PLURY	W1 40.0 TONS 5.0 - 6.5	W1 40.0 TONS 5.0 - 6.5	W1 40.0 TONS 5.0 - 6.5	W1 65.0 TONS 7.0 - 15.0	W1 65.0 TONS 7.0 - 15.0	W1 65.0 TONS 7.0 - 15.0	W1 95.0 TONS 8.0 - 22.0	W1 95.0 TONS 8.0 - 22.0	W1 95.0 TONS 8.0 - 22.0
A (mm)	680	680	680	840	840	840	840	840	840
B (mm)	540	540	540	670	670	670	670	670	670
C (mm)	272	272	272	332	332	332	332	332	332
D (mm)	395	395	395	515	515	515	515	515	515
Weight (Kg)	190	190	190	330	330	330	340	340	340
Engine (CC)	21	27	32	32	43	47	32	43	51
Hydraulic Fluid Flow Rate (L/Min)	45	57	69	69	93	101	69	93	101
Pressure (BAR)	200/220	200/220	200/220	200/220	200/220	200/220	200/220	200/220	200/220
Rev/min (RPM)	2.133	2.111	2.143	2.133	2.111	2.143	2.133	2.111	2.143
Centrifugal force (Kn)	40	40	40	65	65	65	95	95	95
Hertz	36	36	36	36	36	36	36	36	36
Back press. Max. (BAR)	15	15	15	15	15	15	15	15	15

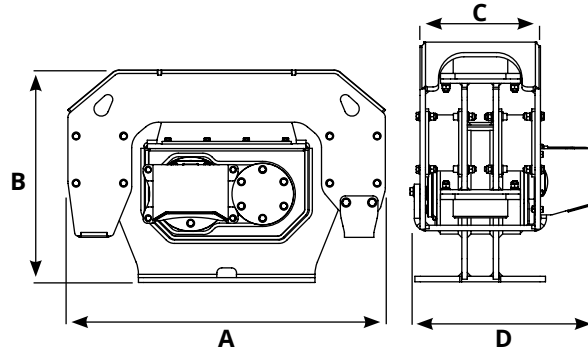

DRAINAGE KIT PLURY
back pressure
MAX 15 BAR

PLURY	W2 60.0	W2 60.0	W2 60.0	W2 80.0	W2 80.0	W2 80.0	W2 100.0	W2 100.0	W2 100.0
	TONS 8.0 - 14.0	TONS 8.0 - 14.0	TONS 8.0 - 14.0	TONS 10.0 - 15.0	TONS 10.0 - 15.0	TONS 10.0 - 15.0	TONS 12.0 - 18.0	TONS 12.0 - 18.0	TONS 12.0 - 18.0
A (mm)	970	970	970	970	970	970	1030	1030	1030
B (mm)	650	650	650	650	650	650	735	735	735
C (mm)	330	330	330	330	330	330	395	395	395
D (mm)	490	490	490	490	490	490	560	560	560
Weight (Kg)	353	353	353	362	362	362	525	525	525
Engine (CC)	32	43	47	32	43	47	43	47	51
Hydraulic Fluid Flow Rate (L/Min)	69	93	101	69	93	101	93	100	110
Pressure (BAR)	200/220	200/220	200/220	200/220	200/220	200/220	200/220	200/220	200/220
Rev/min (RPM)	2.133	2.148	2.143	2.133	2.148	2.143	2.143	2.149	2.157
Centrifugal force (Kn)	60	60	60	80	80	80	100	100	100
Hertz	36	36	36	36	36	36	36	36	36
Back press. Max. (BAR)	15	15	15	15	15	15	15	15	15

PLURY	W2 120.0	W2 120.0	W2 120.0	W2 150.0	W2 180.0
	TONS 14.0 - 20.0	TONS 14.0 - 20.0	TONS 14.0 - 20.0	TONS 18.0 - 35.0	TONS 20.0 - 40.0
A (mm)	1030	1030	1030	1220	1220
B (mm)	735	735	735	920	920
C (mm)	395	395	395	440	440
D (mm)	560	560	560	710	710
Weight (Kg)	533	533	533	827	837
Engine (CC)	43	47	51	63	63
Hydraulic Fluid Flow Rate (L/Min)	93	100	110	135	135
Pressure (BAR)	200/220	200/220	200/220	250/300	250/300
Rev/min (RPM)	2.143	2.149	2.157	2.143	2.143
Centrifugal force (Kn)	120	120	120	150	180
Hertz	36	36	36	36	36
Back press. Max. (BAR)	15	15	15	15	15