

MALAGUTI
EARTHMOVING EQUIPMENT



TORNADO

**STUMP
GRINDER**

DIRECT TRANSMISSION

THE DIRECT DRIVE SYSTEM WITH PISTON MOTOR DELIVERS THE HIGHEST CUTTING SPEED AND THUS OPTIMAL PRODUCTIVITY AND EFFICIENCY

TUNGSTEN CARBIDE TEETH

EXTREMELY RESISTANT TUNGSTEN TEETH

SUITABLE ON DIFFICULT GRADIENTS

EFFECTIVE EVEN ON DIFFICULT GRADIENTS, IDEAL FOR GRINDING EVEN STUMPS WITH PROBLEMATICAL ACCESS

QUICK AND EFFECTIVE

THE SHREDDING WHEEL SWINGS FROM SIDE TO SIDE AND GRADUALLY EATS INTO THE STUMP UNTIL IT HAS BEEN ELIMINATED

TORNADO

MALAGUTI

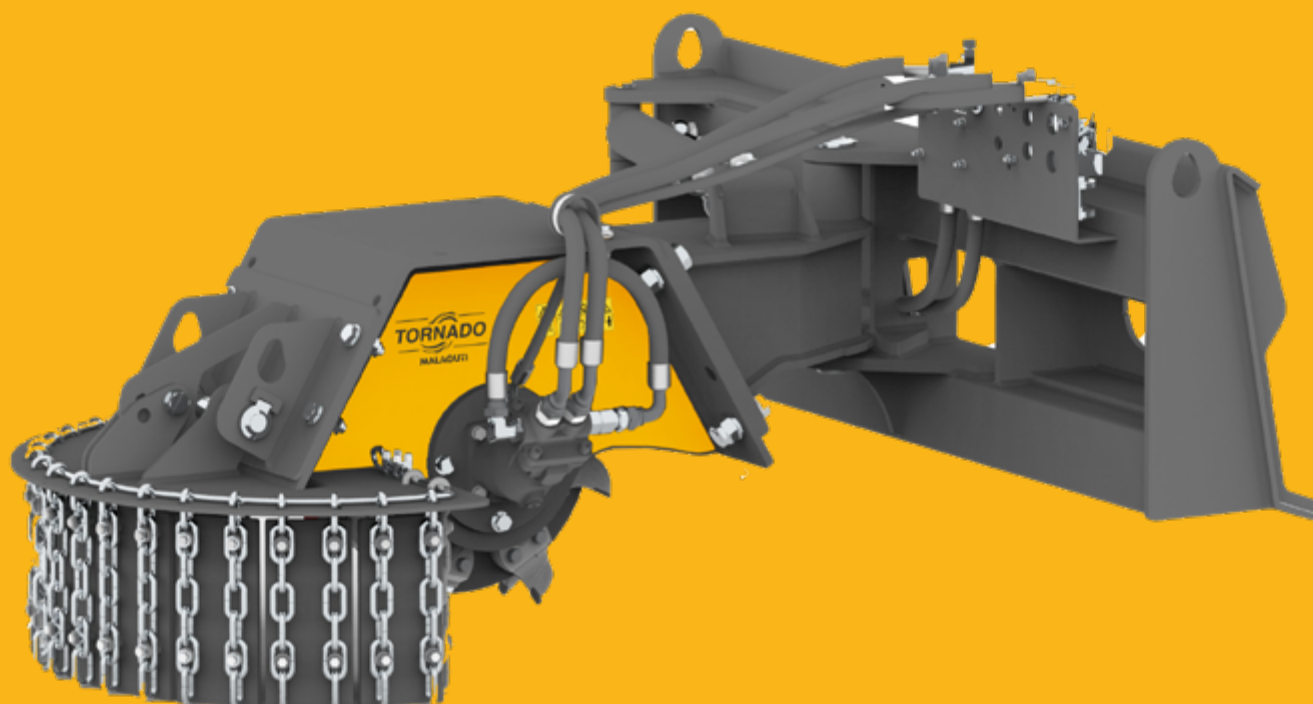

STUMP GRINDER EXCAVATOR

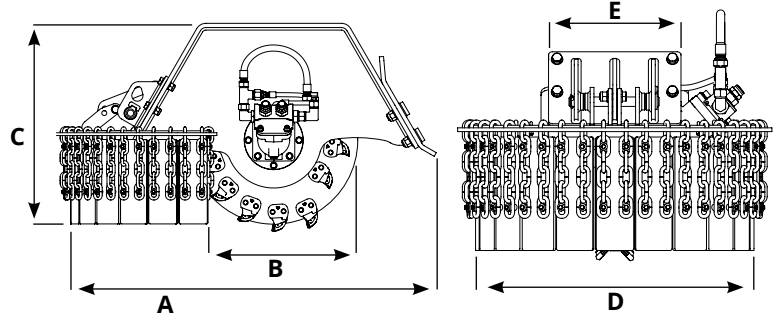

TORNADO	Tornado 350	Tornado 350	Tornado 450	Tornado 450	Tornado 450	Tornado 600	Tornado 600	Tornado 600	Tornado 600 PLUS
TONS	1.5 - 4.5	1.5 - 4.5	4.5 - 9.0	4.5 - 9.0	4.5 - 9.0	9.0 - 13.0	9.0 - 13.0	9.0 - 13.0	13.0 - 18.0
A (mm)	930	930	1150	1150	1150	1360	1360	1360	1360
B (Ømm)	350	350	450	450	450	600	600	600	600
C (mm)	494	494	572	572	572	740	740	740	740
D (mm)	710	710	720	720	720	840	840	840	840
E (mm)	350	350	350	350	350	350	350	350	350
Engine (CC)	12	18	25	28	32	45	50	63	80
Hydraulic Fluid Flow Rate (L/Min)	16	24	32	36	42	56	64	80	110
Without coupling weight (Kg)	140	140	226	226	226	360	360	360	375
Teeth number	16	16	20	20	20	28	28	28	28
Pressure (BAR)	200-250	200-250	200-250	200-250	200-250	200-250	200-250	200-250	200-250
Back press. Max. (BAR)	15	15	15	15	15	15	15	15	15

	Model	A mm	B mm	C mm	Kg.
1	ADAPTER FOR QUICK COUPLING for 350	/	/	/	/
	ADAPTER FOR QUICK COUPLING for 450	/	/	/	/
	ADAPTER FOR QUICK COUPLING for 600	/	/	/	/
2	FIXED COUPLING MACHINE for 350	/	/	/	/
	FIXED COUPLING MACHINE for 450	/	/	/	/
	FIXED COUPLING MACHINE for 600	/	/	/	/
3	BOLTED PLATE MACHINE COUPLING for 350	350	280	10	13
	BOLTED PLATE MACHINE COUPLING for 450	380	350	12	17
	BOLTED PLATE MACHINE COUPLING for 600	470	280	15	16.5

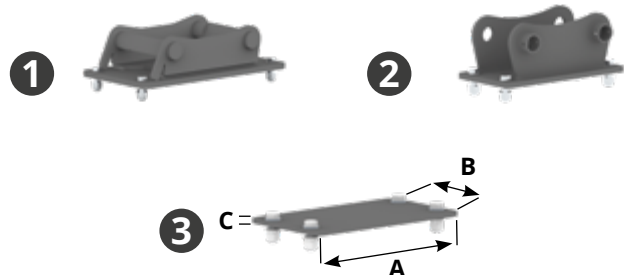

TORNADO F



FRONT-MOUNTED STUMP GRINDER

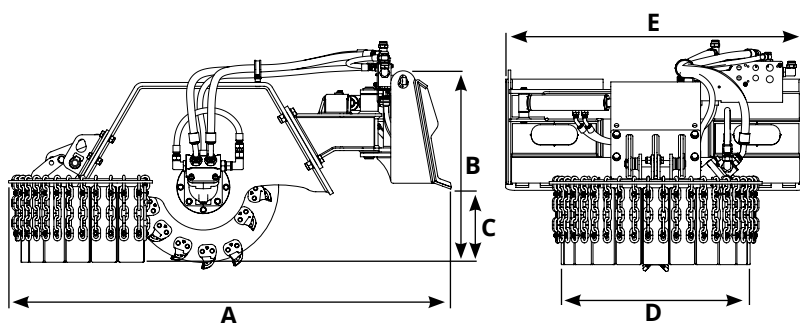
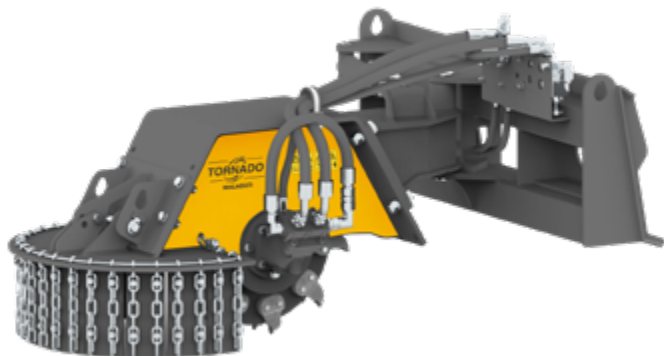

TORNADO	Tornado 350 F	Tornado 350 F	Tornado 450 F	Tornado 450 F	Tornado 450 F	Tornado 600 F	Tornado 600 F	Tornado 600 F	Tornado 600 F PLUS
A (mm)	1366	1366	1529	1529	1529	1734	1734	1734	1734
B (Ømm)	625	625	678	678	678	758	758	758	758
C (mm)	156	156	209	209	209	289	289	289	289
D (mm)	710	710	720	720	720	840	840	840	840
E (mm)	1170	1170	1170	1170	1170	1170	1170	1170	1170
Engine (CC)	12	18	25	28	32	45	50	63	80
Hydraulic Fluid Flow Rate (L/Min)	16	24	32	36	42	56	64	80	80
With coupling weight (Kg)	310	310	393	393	393	530	530	530	545
Teeth number	16	16	20	20	20	28	28	28	28
Pressure (BAR)	200-250	200-250	200-250	200-250	200-250	200-250	200-250	200-250	200-250
Backpress. Max. (BAR)	15	15	15	15	15	15	15	15	15

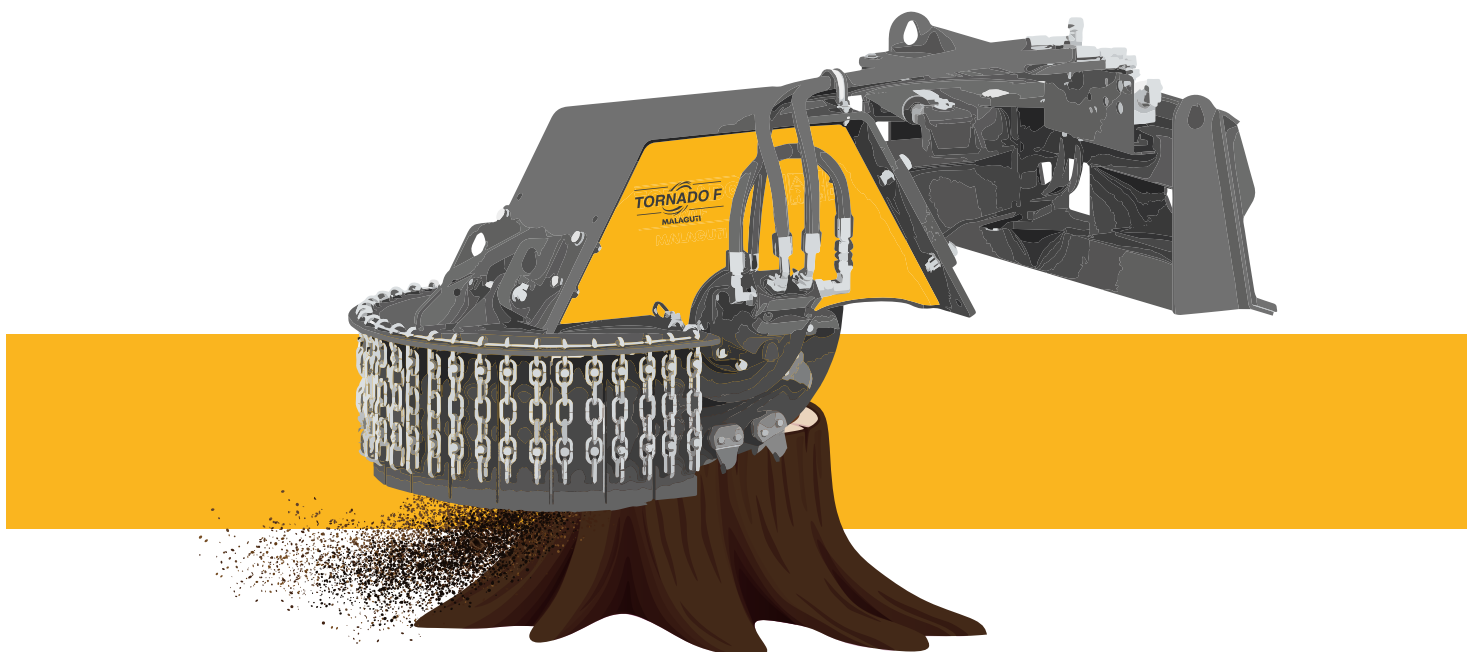



FRONT-MOUNTED ATTACHMENT

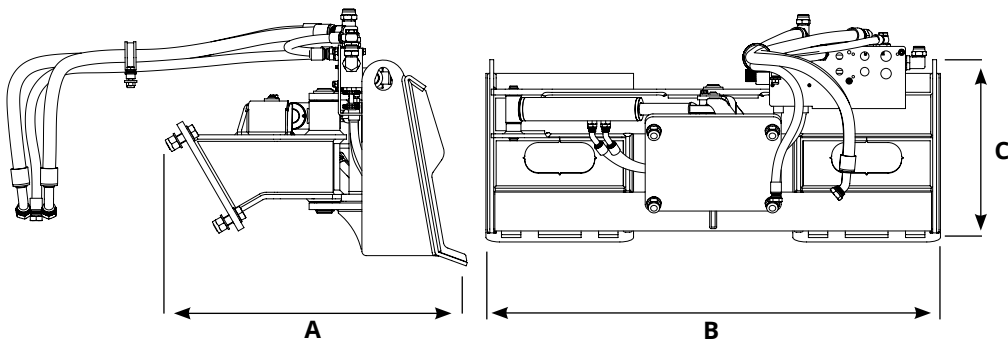
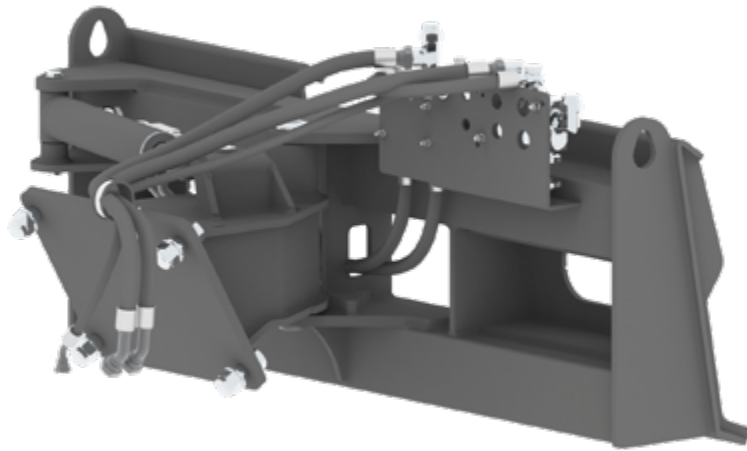

- › Through the use of the Tornado front attachment, it is possible to use the stump grinder on machines such as skid loader, mini skid loader, mini wheel loader

Model	A mm	B mm	C mm	Kg.
FRONT-MOUNTED ATTACHMENT TORNADO for 350 / 450 / 600	436	1170	469	170

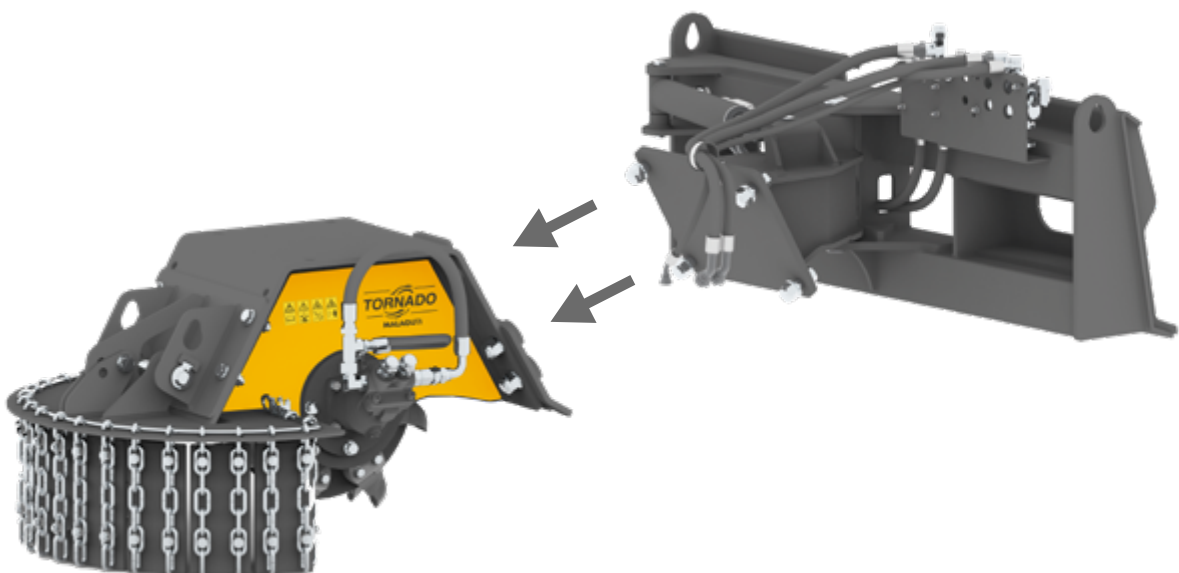

MALAGUTI

EARTHMOVING EQUIPMENT

 **Officine Malaguti SRL**
Sant'Agata Bolognese (BO)
Italy

Ufficio Commerciale
 +39 0547 1932186
 commerciale@malagutisrl.com

 Piazza Plauto, 40
47027 Sarsina (FC)
Italy

 www.malagutisrl.com

