

GRAPPLE

WOOD GRAPPLE WITH BELL

- > Designed for vibro-driving and extraction of wooden, concrete and steel poles
- > Suitable for the containment of landslides, docks, and embankments
- > Construction of vineyards, orchards and fences
- > A fundamental combination that is used in land maintenance and agriculture

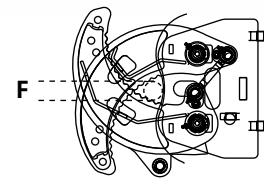
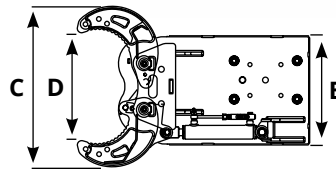
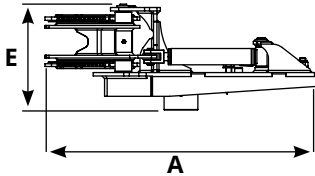

Model	A mm	B mm	C mm	D mm	E mm	F Ø mm	Kg.	Model. PLURY
GRAPPLE 1/4 ton	810	380	560	375	310	35	75	W1 9.0 W1 15.0
GRAPPLE 4/6.5 ton	1090	460	665	425	420	55	159	W1 27.0 W1 40.0
GRAPPLE 7/15 ton	1575	705	870	560	520	140	365	W1 65.0 W2 60.0 W2 80.0
GRAPPLE 8/20 ton	1590	705	870	570	520	140	375	W1 95.0 W2 100.0 W2 120.0
GRAPPLE 18/40 ton	1730	705	870	560	530	140	380	W2 150.0 W2 180.0

Hydraulic Fluid Flow Rate (L/Min) 10

Pressure (BAR) 200



Grapple has the possibility of mounting the customized bell, available in various diameters according to one's needs. The bell is included in the price of the Grapple.

Model	A mm	B mm	C mm	Kg	Model. PLURY
BELL 150 - 1/4 ton	150	200	125	15	W1 9.0 W1 15.0
BELL 200 - 1/4 ton	200	250	125	20	W1 9.0 W1 15.0
BELL 150 - 4/6.5 ton	150	200	105	11	W1 27.0 W1 40.0
BELL 200 - 4/6.5 ton	200	250	125	22	W1 27.0 W1 40.0
BELL 250 - 4/6.5 ton	250	300	145	28	W1 27.0 W1 40.0
BELL 150 - 7/40 ton	150	200	105	17	W1 65.0 W1 95.0 W2 60.0 W2 80.0 W2 100.0 W2 120.0 W2 150.0 W2 180.0
BELL 200 - 7/40 ton	200	250	105	20	W1 65.0 W1 95.0 W2 60.0 W2 80.0 W2 100.0 W2 120.0 W2 150.0 W2 180.0
BELL 250 - 7/40 ton	250	300	125	22	W1 65.0 W1 95.0 W2 60.0 W2 80.0 W2 100.0 W2 120.0 W2 150.0 W2 180.0
BELL 300 - 7/40 ton	300	350	180	43	W1 65.0 W1 95.0 W2 60.0 W2 80.0 W2 100.0 W2 120.0 W2 150.0 W2 180.0
BELL 350 - 7/40 ton	350	400	180	50	W1 65.0 W1 95.0 W2 60.0 W2 80.0 W2 100.0 W2 120.0 W2 150.0 W2 180.0

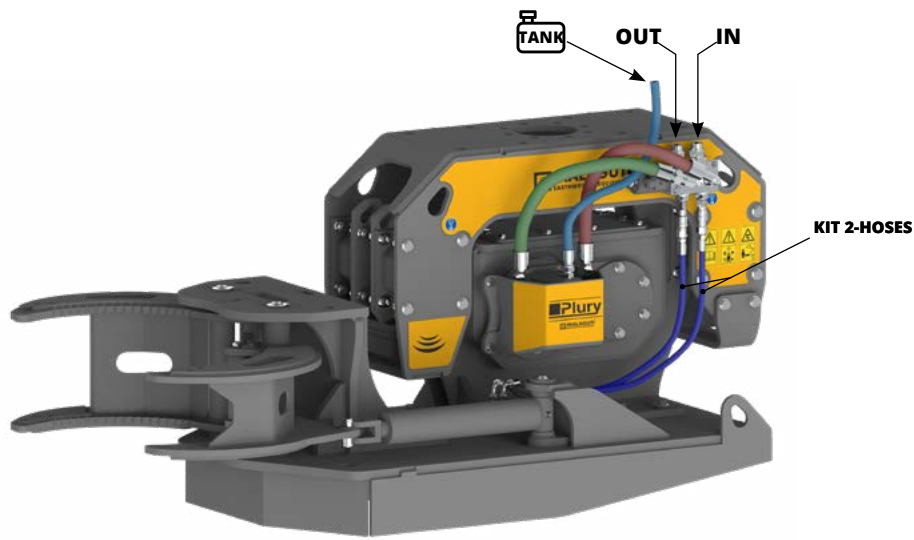

Model KIT	HYDRAULIC KITS	Model. PLURY	Motor (cc)	Cod.
KIT A - PLURY	2-HOSES VALVE KIT 12Volt	W1 9.0 W1 15.0	11	HII0201013
KIT B - PLURY	2-HOSES VALVE KIT 12Volt	W1 27.0 W1 40.0	21 27 32	HII0201006
KIT C - PLURY	2-HOSES VALVE KIT 24Volt	W1 27.0 W1 40.0	21 27 32	HII0201035
KIT D - PLURY	2-HOSES VALVE KIT 12Volt	W1 65.0 W1 95.0 W2 60.0 W2 80.0 W2 100.0 W2 120.0	32 43 47 51	HII0201010
KIT E - PLURY	2-HOSES VALVE KIT 24Volt	W1 65.0 W1 95.0 W2 60.0 W2 80.0 W2 100.0 W2 120.0	32 43 47 51	HII0201037
KIT F - PLURY	2-HOSES VALVE KIT 12Volt	W2 150.0 W2 180.0	63	HII0201012
KIT G - PLURY	2-HOSES VALVE KIT 24Volt	W2 150.0 W2 180.0	63	HII0201038



Model	Model. PLURY	Cod.
A - 2 HOSES GRAPPLE	W1 9.0 W1 15.0	HII0201020
B - 2 HOSES GRAPPLE	W1 27.0 W1 40.0	HII0201022
C - 2 HOSES GRAPPLE	W1 65.0 W1 95.0 W2 60.0 W2 80.0	HII0201024
D - 2 HOSES GRAPPLE	W2 100.0 W2 120.0	HII0201026
C - 2 HOSES GRAPPLE	W2 150.0 W2 180.0	HII0201028



Model	Cod.
ELECTRICAL KIT	C030201020

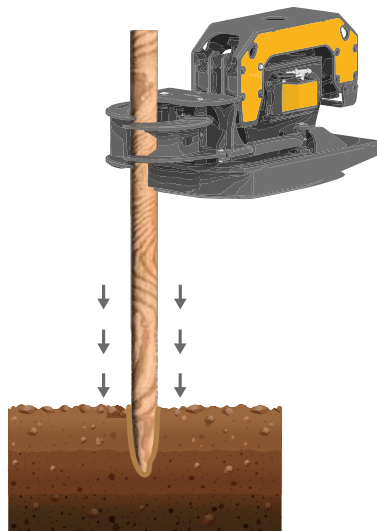

OPTIONAL GRAPPLE KIT

OPTIONAL CONCRETE-STEEL

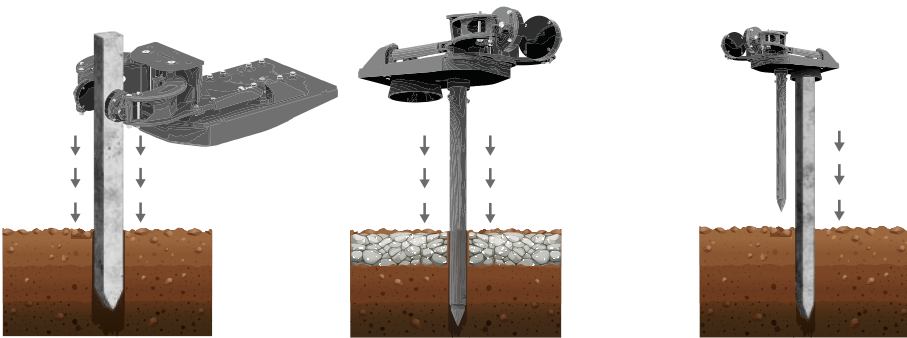
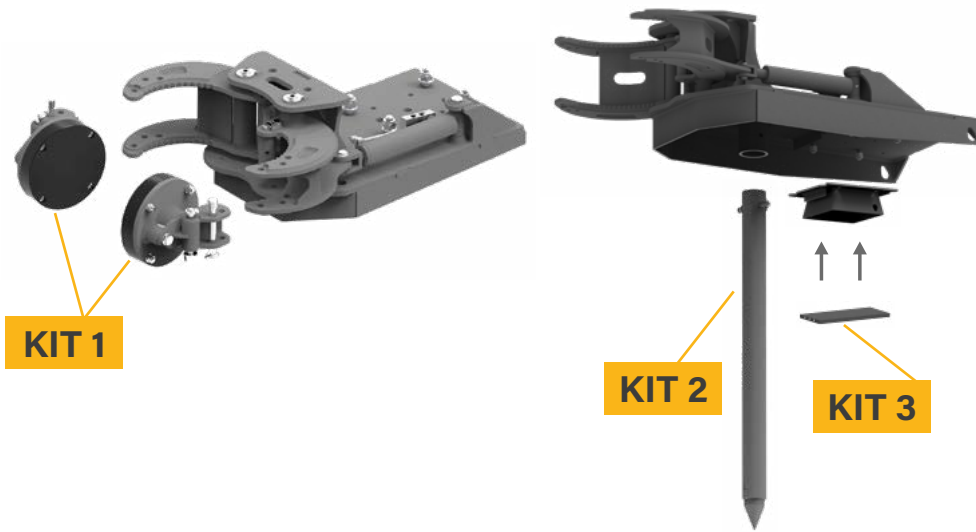

KIT 1

- › Grapple accessory suitable for vibro-driving and extraction of concrete and steel poles

KIT 2

- › Pre-hole drill suitable for making a pre-hole in hard ground
- › Suitable for vibro-driving concrete poles

KIT 3

- › Shock-absorbing rubber accessory suitable for vibrating concrete poles, avoiding damage to the pole itself

TOOTHED PLATE FOR GRAPPLE

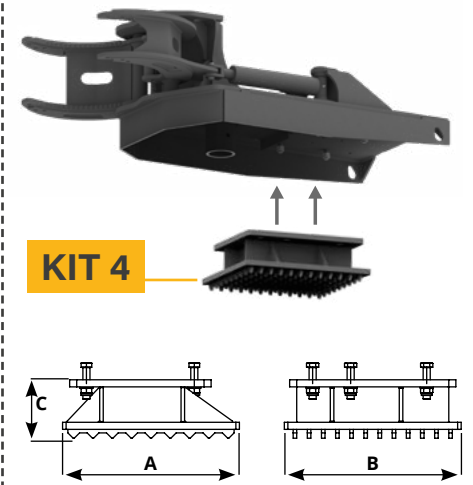

KIT 4

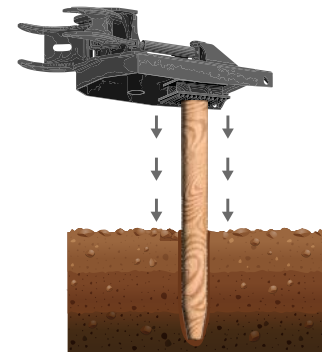
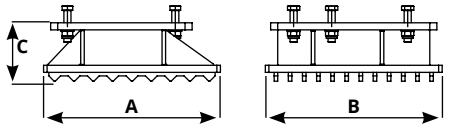

KIT 4

- › Toothed plate mounted in place of the bell for vibratory driving of wooden piles of different diameters

Model	A mm	B mm	C mm	Kg.	Model. GRAPPLE
KIT 1 - 1/4 ton	/	/	/	16	GRAPPLE 1/4 ton
KIT 2 - 1/6.5 ton	/	/	/	22	
KIT 3 for Bell	depending on the type of bell				
KIT 4 - 1/4 ton	335	270	120	23	

Model	A mm	B mm	C mm	Kg.	Model. GRAPPLE
KIT 1 - 4/6.5 ton	/	/	/	20	GRAPPLE 4/6.5 ton
KIT 2 - 1/6.5 ton	/	/	/	22	
KIT 3 for Bell	depending on the type of bell				
KIT 4 - 4/6.5 ton	350	400	130	44	

Model	A mm	B mm	C mm	Kg.	Model. GRAPPLE
KIT 1 - 7/40 ton	/	/	/	24	GRAPPLE 7/15 ton
KIT 2 - 7/20 ton	/	/	/	27	
KIT 3 for Bell	depending on the type of bell				GRAPPLE 8/20 ton
KIT 4 - 7/20 ton	500	500	165	90	

Model	A mm	B mm	C mm	Kg.	Model. GRAPPLE
KIT 1 - 7/40 ton	/	/	/	24	GRAPPLE 18/40 ton
KIT 2 - 18/40 ton	/	/	/	43	
KIT 3 for Bell	depending on the type of bell				
KIT 4 - 18/40 ton	540	500	175	100	