

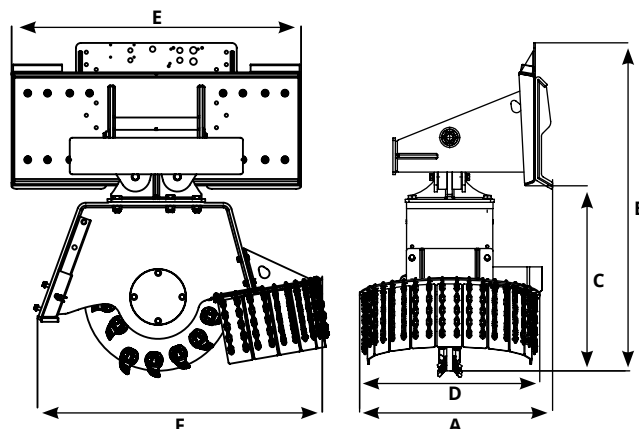

TRANSVERSE FRONT STUMP GRINDER for SKID LOADER and WHEEL LOADER



TORNADO 2FT			Tornado 2FT 350			Tornado 2FT 450			Tornado 2FT 600			Tornado 2FT 600 PLUS		
A (mm)			720			720			780			780		
B (Ømm)			1060			1160			1325			1325		
C (mm)			480			570			750			750		
D (mm)			610			610			730			730		
E (mm)			1170			1170			1170			1170		
F (mm)			760			900			1150			1150		
Engine (CC)	Hydraulic Fluid Flow Rate (L/Min)	Rev/min (RPM)	12	16	1330	25	32	1280	45	56	1290	80	110	1375
			18	24	1330	28	36	1280	50	64	1300			
			25	32	1280	32	42	1315	63	80	1300			
			28	36	1280									
			32	42	1315									
Weight (Kg)			246			300			408			408		
Teeth number			16			20			28			28		
Pressure (BAR)			250			250			250			250		
Backpress. Max. (BAR)			15			15			15			15		

Model KIT	HYDRAULIC KIT	Model Tornado	Engine (cc)	Cod.
KIT A - 2FT	HYDRAULIC KIT 4 HOSES + DRAINAGE WITH MOTOR FLOW ADJUSTMENT	350	12cc 18cc	HIIXX01036
KIT B - 2FT	HYDRAULIC KIT 4 HOSES + DRAINAGE WITH MOTOR FLOW ADJUSTMENT	350 450	25cc 28cc 32cc	HIIXX01037
KIT C - 2FT	HYDRAULIC KIT 4 HOSES + DRAINAGE WITH MOTOR FLOW ADJUSTMENT	600 600 plus	45cc 50cc 63cc 80cc	HIIXX01038
KIT D - 2FT	HYDRAULIC KIT 4 HOSES + DRAINAGE (adjustment is managed by the host machine)	350	12cc 18cc	HIIXX01039
KIT E - 2FT	HYDRAULIC KIT 4 HOSES + DRAINAGE (adjustment is managed by the host machine)	350 450	25cc 28cc 32cc	HIIXX01040
KIT F - 2FT	HYDRAULIC KIT 4 HOSES + DRAINAGE (adjustment is managed by the host machine)	600 600 plus	45cc 50cc 63cc 80cc	HIIXX01041

Model
COUPLING TO LOADER Supplement for BLADES

